

ITEM NO.	PART NUMBER	DESCRIPTION	QTY.
1	08-805	Chain Wheel	2
2	08-825	5/16" Chain Wheel Bearing	4
3	08-809	Chain wheel Bearing Spacer	2
4	975-05-ANFW	5/16 AN Washer	4
5	08-010	Chain Tensioner Strap	2
6	08-822	Chain Strap Spacer	1
7	08-815	Dual Tensioner Arm	1
8	973-05-18-1	5/16-18 x 1.00 FHCS	2
9	977-05-24	5/16-24 Nylock Full nut	2
10	974-05-18-2	5/16-18 x 2.00 Shoulder Bolt	2
12	975-05-WIDEFW	5/16 Wide Flat Washer	3
13	977-04-20	1/4-20 Nylock Full Nut	2

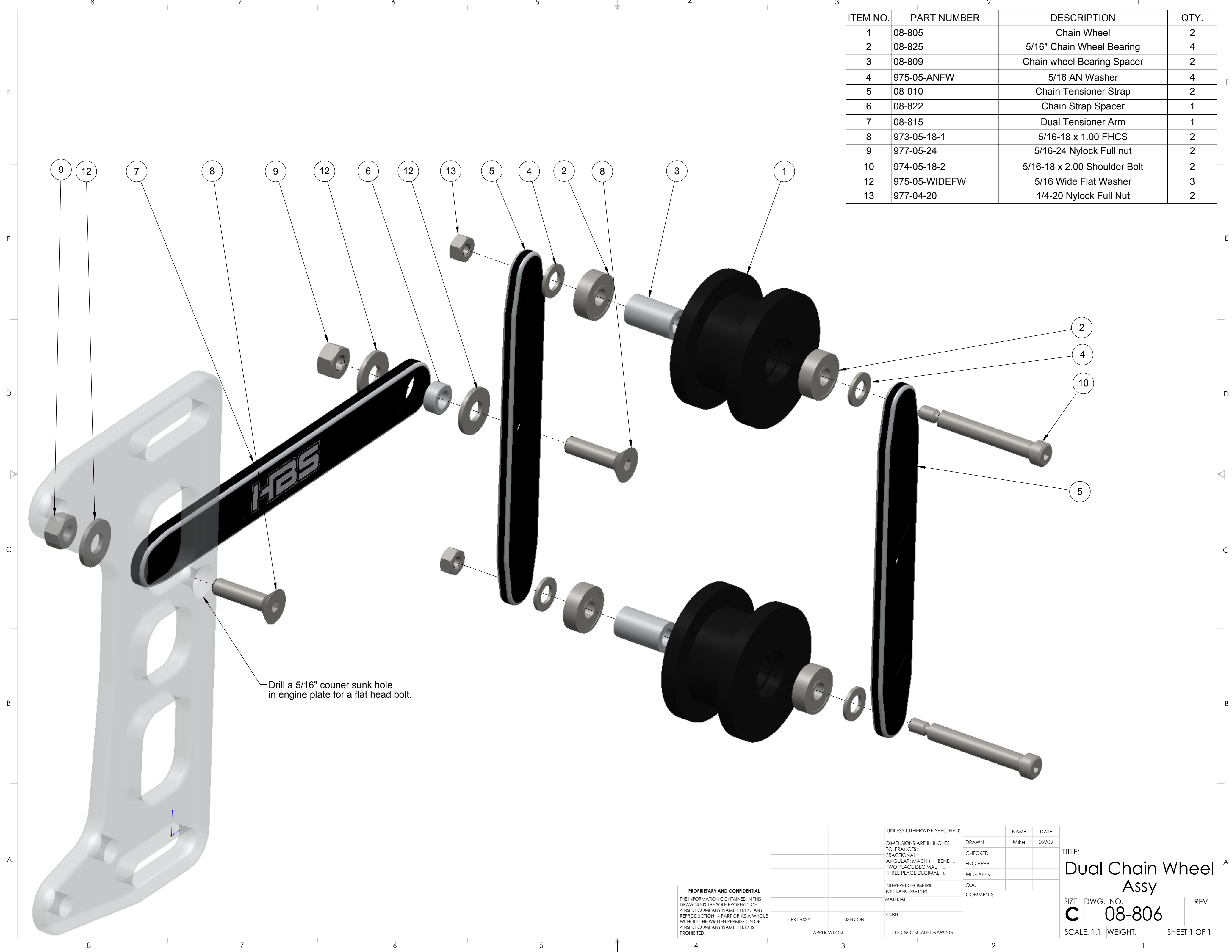

Drill a 5/16" couner sunk hole
in engine plate for a flat head bolt.

PROPRIETARY AND CONFIDENTIAL
THE INFORMATION CONTAINED IN THIS
DRAWING IS THE SOLE PROPERTY OF
<INSERT COMPANY NAME HERE>. ANY
REPRODUCTION IN PART OR AS A WHOLE
WITHOUT THE WRITTEN PERMISSION OF
<INSERT COMPANY NAME HERE> IS
PROHIBITED.

UNLESS OTHERWISE SPECIFIED:		NAME	DATE
DIMENSIONS ARE IN INCHES		DRAWN	Mike 09/09
TOLERANCES:		CHECKED	
FRACTIONAL ±		ENG APPR.	
ANGULAR: MATCH ± BEND ±		MFG APPR.	
TWO PLACE DECIMAL ±		Q.A.	
THREE PLACE DECIMAL ±		COMMENTS:	
INTERPRET GEOMETRIC TOLERANCING PER:			
MATERIAL			
FINISH			
NEXT ASSY	USED ON		
APPLICATION	DO NOT SCALE DRAWING		

TITLE:
**Dual Chain Wheel
Assy**

SIZE DWG. NO. REV
C **08-806**

SCALE: 1:1 WEIGHT: SHEET 1 OF 1